

Owner's Manual & Assembly Instructions

BP01

Model No. EH54-A EN54 HM5467
 LM5467 RM54-A RMG54
 RMW54 VL5467 WL54

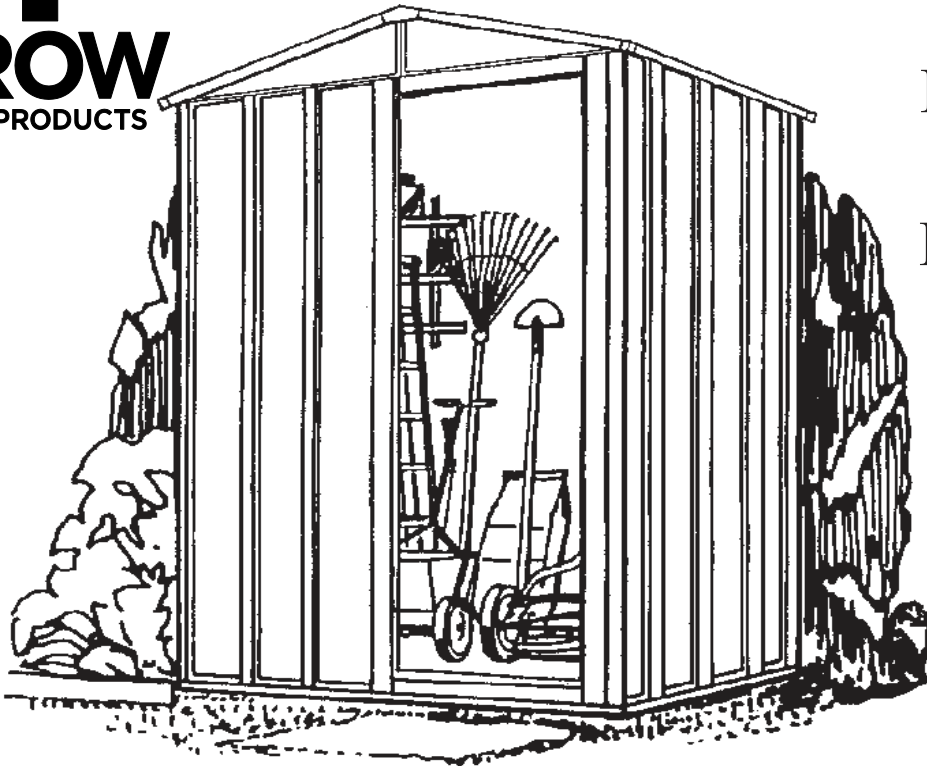

NW54
 RMG54Z
 SE5467
 RMG54EU
 SE5467EU
 WL54EU

Missing Parts, Questions on Assembly?

Call: 1-800-851-1085 or
assist@arrowsheds.com

Do not return to dealer, they are not
 equipped to handle your requests.

709241216

Storage Area: 16 Sq. Ft. 98 Cu. Ft.
 1,5 m² 2,8 m³



CAUTION: SOME PARTS HAVE SHARP EDGES. CARE MUST BE TAKEN WHEN HANDLING THE VARIOUS PIECES TO AVOID A MISHAP. FOR SAFETY SAKE, PLEASE READ SAFETY INFORMATION PROVIDED IN THIS MANUAL BEFORE BEGINNING CONSTRUCTION. WEAR GLOVES WHEN HANDLING METAL PARTS.

BUILDING DIMENSIONS * Size rounded off to the nearest foot

*Approx. Size	Base Size	Exterior Dimensions (Roof Edge to Roof Edge)			Interior Dimensions (Wall to Wall)			Door Opening	
		Width	Depth	Height	Width	Depth	Height	Width	Height
5' x 4'	57" x 45 7/8"	59 1/2"	48"	78"	54 1/4"	43 1/8"	76 3/4"	22 1/4"	65"
1,4 m x 1,1 m	144,8 cm x 116,5 cm	151,1 cm	121,9 cm	198,1 cm	137,8 cm	109,5 cm	194,9 cm	56,5 cm	165,1 cm

- GB:** Assembly manual in additional languages available online.
Scan QR code below to access.
- FR:** Manuel de montage disponible en ligne dans d'autres langues.
Pour y accéder, scannez le code QR ci-dessous.
- SP:** Manual de montaje en idiomas adicionales disponible online.
Escanee el código QR a continuación para acceder.
- DE:** Montageanleitung in zusätzlichen Sprachen online verfügbar.
Scannen Sie den QR-Code unten, um darauf zuzugreifen.
- IT:** Manuale dell'assemblea in altre lingue disponibile online.
Per accedere effettua la scansione del codice QR in basso.
- PT:** Manual de montagem disponível em outros idiomas online.
Digitalize o código QR abaixo para obter acesso.
- DT:** Samlingshåndbog i yderligere sprog til rådighed online.
Scan QR kode nedenunder for at få adgang.
- SK:** Na internete je k dispozícii návod na zostavenie v ďalších jazykoch.
Dostanete sa k nemu naskenovaním kódu QR.
- CZ:** Návod k montáži v dalších jazycích je k dispozici v online verzi.
Přístup získáte po naskenování QR kódu níže.
- HU:** Az összeszerelési útmutató további nyelveken is elérhető online.
A hozzáféréshez olvassa be az alábbi QR-kódot.
- GR:** Υπάρχει διαθέσιμο στο διαδίκτυο το εγχειρίδιο συναρμολόγησης
σε περισσότερες γλώσσες. Σαρώστε τον παρακάτω κώδικα
QR για να αποκτήσετε πρόσβαση.



BEFORE YOU BEGIN...

A03

Owner's Manual

Before beginning construction, check local building codes regarding footings, location and other requirements. Study and understand this owner's manual.

Important information and helpful tips will make your construction easier and more enjoyable.

Assembly Instructions: Instructions are supplied in this manual and contain all appropriate information for your building model. Review all instructions before you begin, and during assembly, follow the step sequence carefully for successful results.

Flooring and Anchoring: Your storage building must be anchored to prevent wind damage. A base is necessary to construct a square and level building. Anchoring and base materials are not included with your building. We recommend the combined use of an Arrow Floor Frame Kit and an Arrow Anchoring Kit as an effective method of securing your building to the ground (Available at your local dealer, Arrow's website arrowsheds.com or call Arrow's Customer Service department 1-800-851-1085) or you may construct a base and anchoring system of your choice. Your assembly instructions provide information on a few methods commonly used to secure and level a storage building.

Parts and Parts List: Check to be sure that you have all the necessary parts for your building.

- All part numbers can be found on the parts. All of these numbers (before the -) must agree with the numbers on the Parts List page.

- If you find that a part is missing, include the model number of your building and contact:

Arrow Shed, LLC Customer Service Department

1101 North 4th Street Breese, Illinois 62230

1-800-851-1085 or assist@arrowsheds.com

- Separate contents of the carton by the part number while reviewing parts list. The first few steps show how to join related parts to make larger sub assemblies which will be used later.

- Familiarize yourself with the hardware and fasteners for easier use during construction. These are packaged within the carton. Note that extra fasteners have been supplied for your convenience.

PLAN AHEAD....

A04

Watch the Weather: Be sure the day you select to install your building is dry and calm. Do not attempt to assemble your building on a windy day. Be careful on wet or muddy ground.

Teamwork: Whenever possible, two or more people should work together to assemble your building. One person can position parts or panels while the other is able to handle the fasteners and the tools.

Tools and Materials: These are some basic tools and materials you will need for the construction of your building. Decide which method of anchoring and the type of base you wish to use in order to form a complete list of the materials you will need.

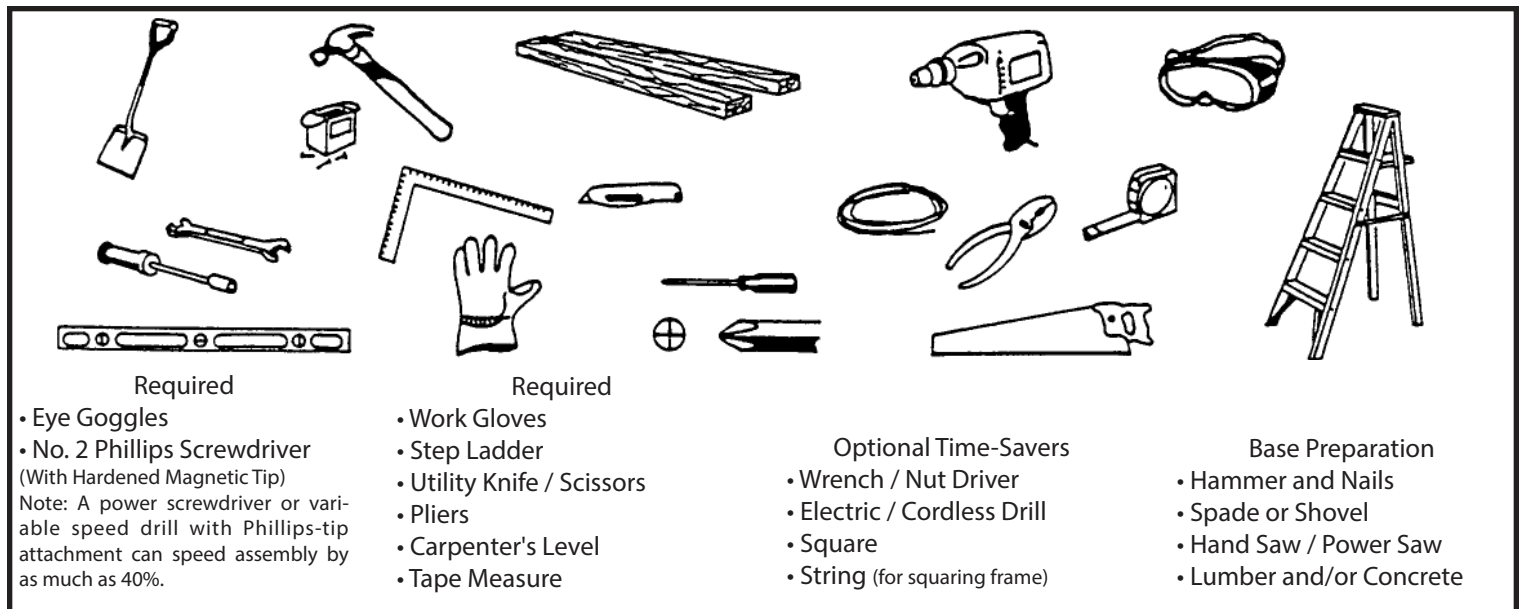

Selecting and Preparing Your Site: Before assembly, you will want to decide on a location for your building. The best location is a level area with good drainage.

- Allow enough working space for ease of moving parts into position during assembly. Be sure there will be enough space at entrance for doors to open fully and enough space around the building to be able to fasten the panel screws from the outside.

- Before you begin the first steps in assembling your parts, a base should be constructed and an anchoring system should be ready to use.

SAFETY FIRST...

Safety precautions are important to follow throughout the construction of your building.

•Care must be taken when handling various pieces of your building since some contain sharp edges. Please wear work gloves, eye protection and long sleeves when assembling or performing any maintenance on your building.

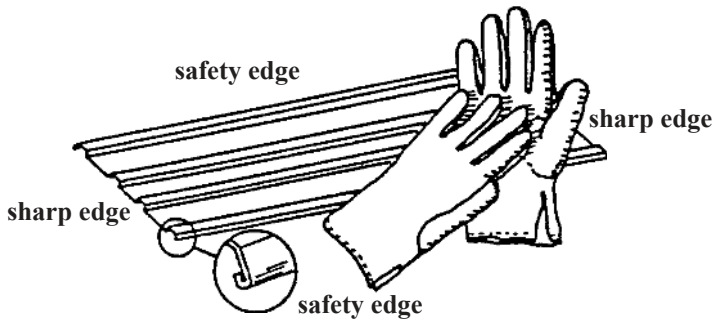

•Keep children and pets away from worksite to avoid distractions and any accidents which may occur.



•Never concentrate your total weight on the roof of the building. When using a step ladder make sure that it is fully open and on even ground before climbing on it.



•Practice caution with the tools being used in the assembly of this building. Be familiar with the operation of all power tools.

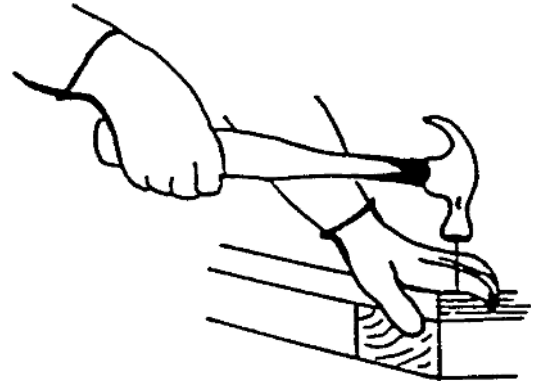

•Do not attempt to assemble the building if parts are missing because any building left partially assembled may be seriously damaged by light winds. Call 1-800-851-1085 or assist@arrowsheds.com

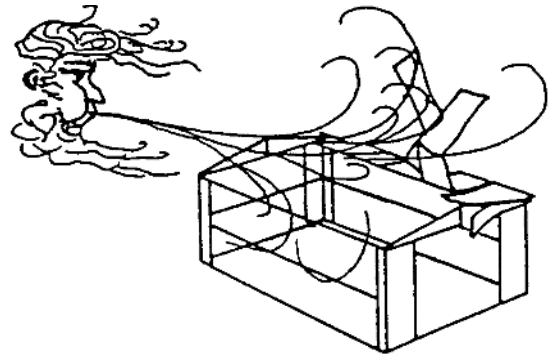

•Do not attempt to assemble the building on a windy day, because the large panels acting as a "sail", can be whipped about by the wind making construction difficult and unsafe.

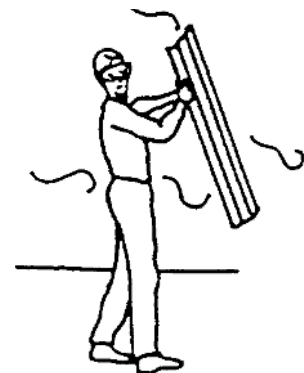

CARE & MAINTENANCE....

A06

Finish: For long lasting finish, periodically clean and wax the exterior surface. Touch-up scratches as soon as you notice them on your unit. Immediately clean the area with a wire brush; wash it and apply touch-up paint per manufacturer's recommendation.

Roof: Keep roof clear of leaves and snow with long handled, soft-bristled broom. Heavy amounts of snow on roof can damage building making it unsafe to enter. In snow country, Roof Strengthening Kits are available for most Arrow Buildings for added protection against heavy snow accumulation. Contact Arrow as outlined on the Ordering Accessories page to place an order.

Doors: Always keep the door tracks clear of dirt and other debris that prevent them from sliding easily. Lubricate door track annually with furniture polish or silicone spray. Keep doors closed and locked to prevent wind damage.

Fasteners: Use all washers supplied to protect against weather infiltration and to protect the metal from being scratched by screws. Regularly check your building for loose screws, bolts, nuts, etc. and retighten them as necessary.

Moisture: A plastic sheet (vapor barrier) placed under the entire floor area with good ventilation will reduce condensation.

Other Tips....

- Wash off inked part numbers on coated panels with soap and water.
- Silicone caulking may be used for watertight seals throughout the building.

Do not store swimming pool chemicals in your building. Combustibles and corrosives must be stored in air tight approved containers.

Keep this Owner's Manual and Assembly Instructions for future reference.

ACCESSORIES...

A07

ROOF STRENGTHENING (heavy snow load) KITS

Extra roof beams and gable braces designed for added protection against heavy snow accumulation. Increases the strength of your roof.

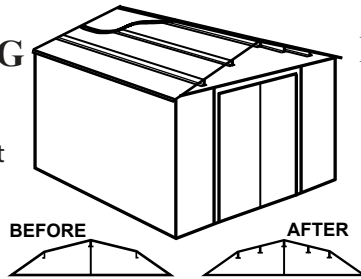

ANCHOR KITS

Model No. AK4

Anchor Kit contains heavy-duty steel augers, 60' (18 m) of steel cable and 4 cable clamps. No digging or concrete pouring, just insert cable under roof, over roof beams, into augers and twist augers into the ground. For buildings larger than 10'x9' (3,0 m x 2,6 m), use 2 kits.

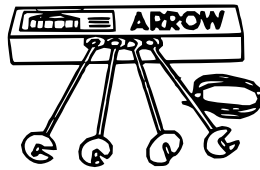

Model No. AK100

New concrete anchor system permits anchoring any size Arrow building directly to a concrete slab. Each kit contains heavy-duty, hot-dipped galvanized steel corner gussets and perimeter clips which fit over the floor frame and lag bolt into a concrete slab. Full assembly instructions and a 1/4" masonry drill bit are included.

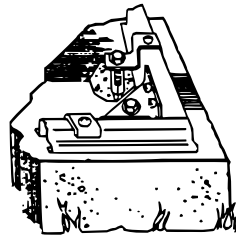

Model No. AK600

Earth Anchor Kit anchors any size Arrow building to the ground. Each kit contains heavy duty, hot-dipped galvanized steel corner gussets and 4 earth anchors.

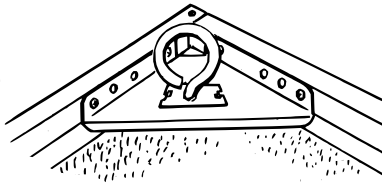

TOOL HANGING RACK

Model No. TH100

The perfect tool organizer. Twin 25 1/2" (64,8 cm) steel channels plus five heavy-duty snap-in hangers and a small tool holder for screwdrivers, pliers, etc. Holders slide along channel for fully adjustable spacing. Great for garage, basement, or the back of any door. Fits all Arrow storage buildings.

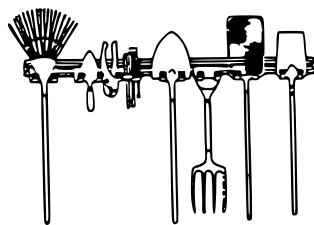

FLOOR FRAME KITS

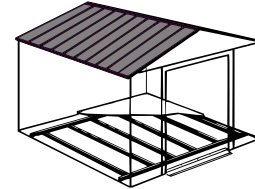

MODELS FB47410, FB5465, FB106-A
FB109-A and FB1014-A

A simple new floor frame system made of heavy-duty, hot-dipped galvanized steel. Use as base for plywood, sand or stone.

ATTIC KIT / WORKBENCH KIT

Model No. AT101

Heavy-duty galvanized steel bars that fit all 10' (3,0 m) wide Arrow buildings. They install quickly and easily to help organize space and create more useable space as an attic or workbench. Will hold up to 250 lbs. (113 kg) evenly distributed.

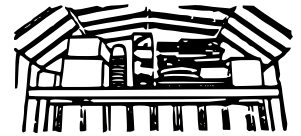

Some drilling required to fit buildings without mid-wall bracing.

SHELF UNITS

Heavy-duty, galvanized steel shelf units help organize storage space. They easily mount on the wall or sit on the floor. Fits all Arrow buildings.*

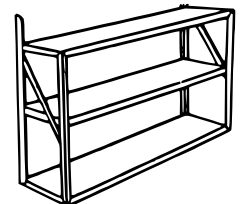
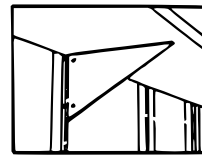
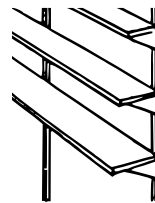

Model No. SS404

- Makes 8" to 12" (20,3-30,5 cm) wide shelves in any length.
- Brackets, braces, hardware included.
- Lumber is not included.

Model No. SS900-B

- Grey color
- 3 shelves
- Holds up to 85 lbs. (38 kg) (even weight distribution)

* Some drilling required to fit buildings without mid-wall bracing.

ORDERING ACCESSORIES....

A08

02/13

We recommend that you purchase accessory items from your local storage building dealer whenever possible; however, because the full line of accessories is not always available from all dealers, Arrow is offering them to you on a direct basis.

There are two ways to order Arrow Storage Building Accessories:

Option 1	Option 2
<p data-bbox="212 720 607 789">Accessories can be purchased through</p> <p data-bbox="302 835 518 863">arrowsheds.com</p>	<p data-bbox="881 724 1425 793">Order accessories by telephone using your MasterCard or Visa credit card.</p> <p data-bbox="967 840 1339 909">Call toll free 1-800-851-1085 (Customer Service).</p> <p data-bbox="979 955 1328 982">Allow 2 weeks for delivery.</p>

SPECIAL NOTE:

If your accessory is shipped via truck line a day time phone number is required to arrange delivery. If no one is available to sign for the delivery, you may be subject to a re-delivery charge assessed by the carrier.

Base

BI09

The Base For Your Building

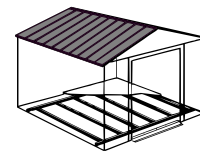

No matter which of the options below you choose for a base, an ARROW ANCHORING KIT is recommended as an effective method of properly securing your building after assembly is complete.

OPTION 1: Directly on ground (earth)

Assemble your building directly on level ground (grass, dirt, rock, sand, etc.). If you choose this option Arrow has a simple kit available to provide a floor inside the shed to keep stored items off the ground. This kit can be used to support a plywood floor (wood not included) or be filled with sand/rock to provide a solid surface. (Order No. FB5465)

Allow 1 - 2 hours for construction.

OPTION 2: Wood Platform

If you decide to build your own base, be sure to select the appropriate materials.

These are the recommended materials for your base:

☒ 2 x 4's (38 mm x 89 mm) Pressure Treated Lumber

☒ 5/8" (15,5 mm) 4 x 8 (1220 mm x 2440 mm) Plywood-exterior grade NOTE: Pressure Treated Lumber must not be used where it will make contact with your storage building. The properties of Pressure Treated Lumber will cause accelerated corrosion.

If Pressure Treated Lumber comes in contact with your storage building your warranty will be voided.

☒ 10 & 4 penny Galvanized Nails ☒ Concrete Blocks (optional)

The platform should be level and flat (free of bumps, ridges etc.) to provide good support for the building. The necessary materials may be obtained from your local lumber yard.

To construct the base follow instructions and diagram.

Construct frame (using 10 penny galvanized nails)

Measure 16"/24" (40,6 cm/61,0 cm) sections to construct inside frame (see diagram)

Secure plywood to frame (using 4 penny galvanized nails)

Allow 6 - 7 hours for construction.

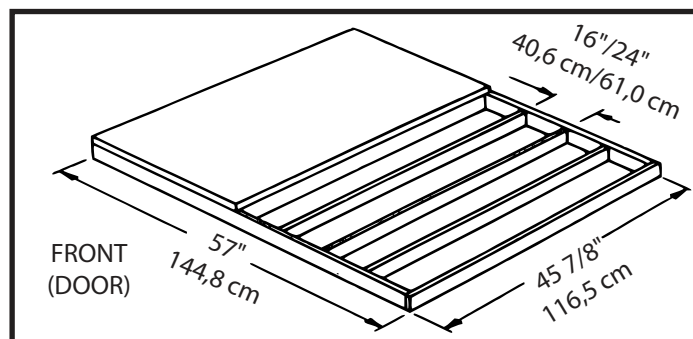

Note: Platform/Slab will extend 9/16" (1,4 cm) beyond floor frame on all four sides. Seal this 9/16" (1,4 cm) of wood with a roofing cement (not included), or bevel this 9/16" (1,4 cm) of concrete when pouring, for good water drainage.

OPTION 3: Concrete Slab

The slab should be at least 4" (10,2 cm) thick. It must be level and flat to provide good support for the frame.

The following are the recommended materials for your base.

☒ 1 x 4's (19 mm x 89 mm) (will be removed once the concrete cures)

☒ Concrete ☒ Sheet of 6 mil plastic

☒ We recommend for a proper strength concrete to use a mix of:
1 part cement ☒ 3 parts pea sized gravel ☒ 2 1/2 parts clean sand

Prepare the Site/Construct a Base

1. Dig a square, 6" (15,2 cm) deep into the ground (remove grass).

2. Fill up to 4" (10,2 cm) in the square with gravel and tamp firm.

3. Cover gravel with a sheet of 6 mil plastic.

4. Construct a wood frame using four planks of 1x4 (19 mm x 89 mm) lumber.

5. Pour in concrete to fill in the hole and the frame giving a total of 4" (10,2 cm) thick concrete. Be sure surface is level.

Allow 3 - 5 hours for construction and a week for concrete curing time.

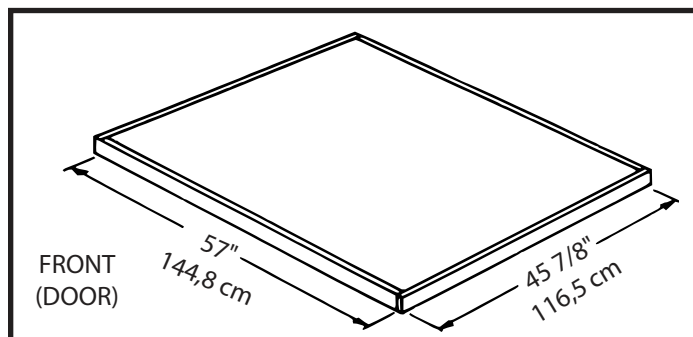

Note: Finished Slab dimensions, with lumber removed.

Anchoring

A10

Anchoring Down The Building

It is important that the entire floor frame be anchored after the building is erected.

Below are recommended ways of anchoring.

Arrow Anchoring Kit: (Model No. AK4 or 60298)

Recommended for use with any suggested base.

Contains: 4 Anchors with Cable, Clamps and installation instruction.

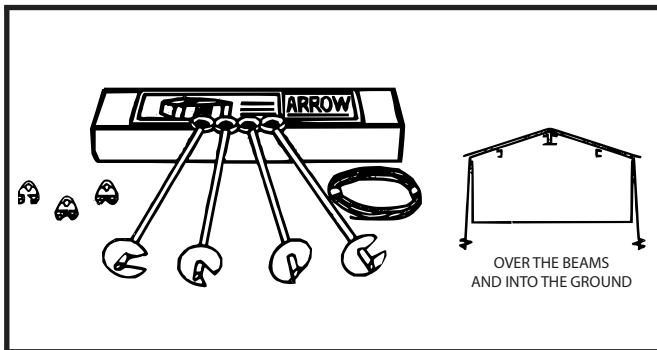

Anchoring into Wood/Post:

Use 1/4" (6 mm) Wood Screws. There are 1/4" (6 mm) dia. holes provided in the frames for proper anchoring.

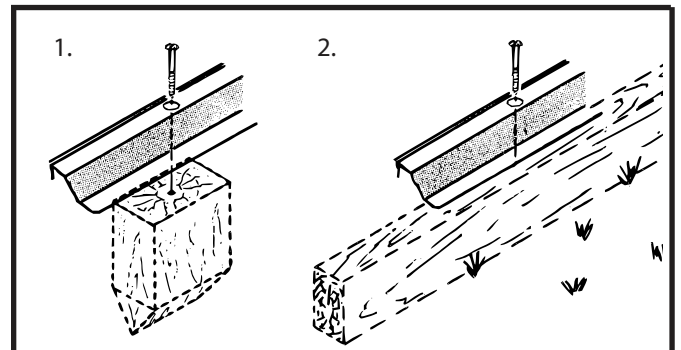

Arrow Anchoring Kit: (Model No. AK100 or 68383)

Recommended for use with the concrete base.

Contains: Corner gussets, perimeter clips, hardware, 1/4" masonry drill bit and installation instruction.

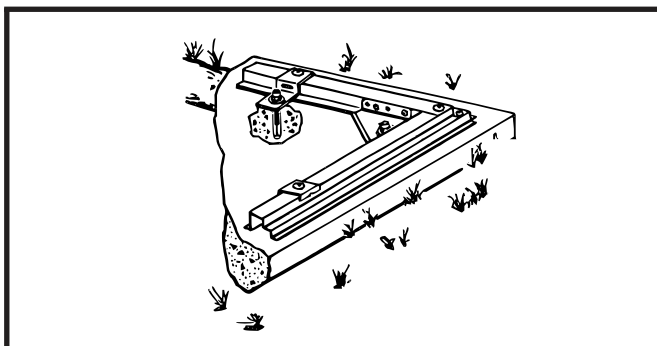

Anchoring into Concrete:

1. For poured concrete slab or footing or patio blocks: Use 1/4" x 2" (6 mm x 51 mm) Lag Screws.
2. For Anchor Post of Concrete poured after building is erected: Use 1/4" x 6" (6 mm x 152 mm) Lag Screws.

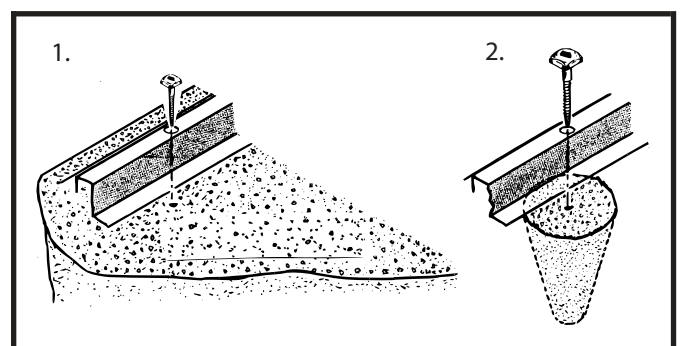

Hardware

BP11

Remove from bag of screws
and save for the last step



65103
#8-32 Hex Nut (35)



65900A
#10Bx1/2" (13 mm)
Black Screw (4)
(Packed with Screws)



65923
#8-32x3/8" (10 mm)
Bolt (35)



65004
#8Ax5/16" (8 mm)
Screw (159)



65914
#6Ax7/8" (22 mm) Screw (2)
(Packed with Screws)

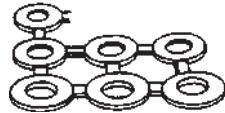

66646
Washer (140)
(4 sheets of 40)



65109
#8-32 Acorn Nut (3)
(Packed with Screws)



66098
Plastic Spacer (2)
(Packed with Screws)



66769
Door Slide (2)

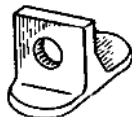

66382
Lower Door Guide (2)

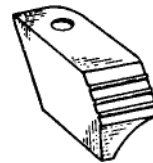

66183
Roof Trim Cap
(2 right & 2 left)



67468
Peak Cap (2)



66775
Plug (1)
(Packed with Screws)

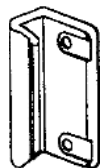

66260
Handle (1)

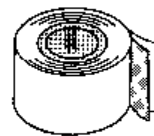

67293
Weather Stripping (1)

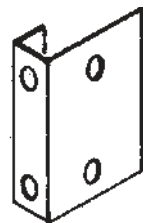

7972
Door Handle Lock Bracket (1)

Parts List

BP12

Assembly Key No.	Part Number	Part Description	Quantity in Carton	Check List
1	3719	Door Handle Brace	1	
2	6300	Vertical Door Brace	1	
3	6627	Wall Panel	1	
4	6633	Corner Panel	2	
5	7044	Corner Panel	2	
6	10500	Horizontal Door Brace	2	
7	10473	Door	1	
8	9725	Rear Wall Angle	1	
9	9726	Right Roof Panel	2	
10	9727	Left Roof Panel	2	
11	9449	Right Gable	2	
12	9448	Left Gable	2	
13	9574	Side Roof Trim	2	
14	9729	Roof Beam	1	
15	9731	Roof Beam Angle	1	
16	9698	Door Jamb	1	
17	9918	Rear Wall Channel	1	
18	9919	Side Wall Channel	2	
19	8971	Side Floor Frame	2	
20	8972	Rear Floor Frame	1	
21	9370	Door Jamb	1	
22	9456	Front Wall Panel	1	
23	9730	Door Track	1	
24	9458	Front Floor Frame	1	
25	9573	Ridge Cap	1	
26	9728	Side Wall Angle	2	

Assembly by Key No.

BP13

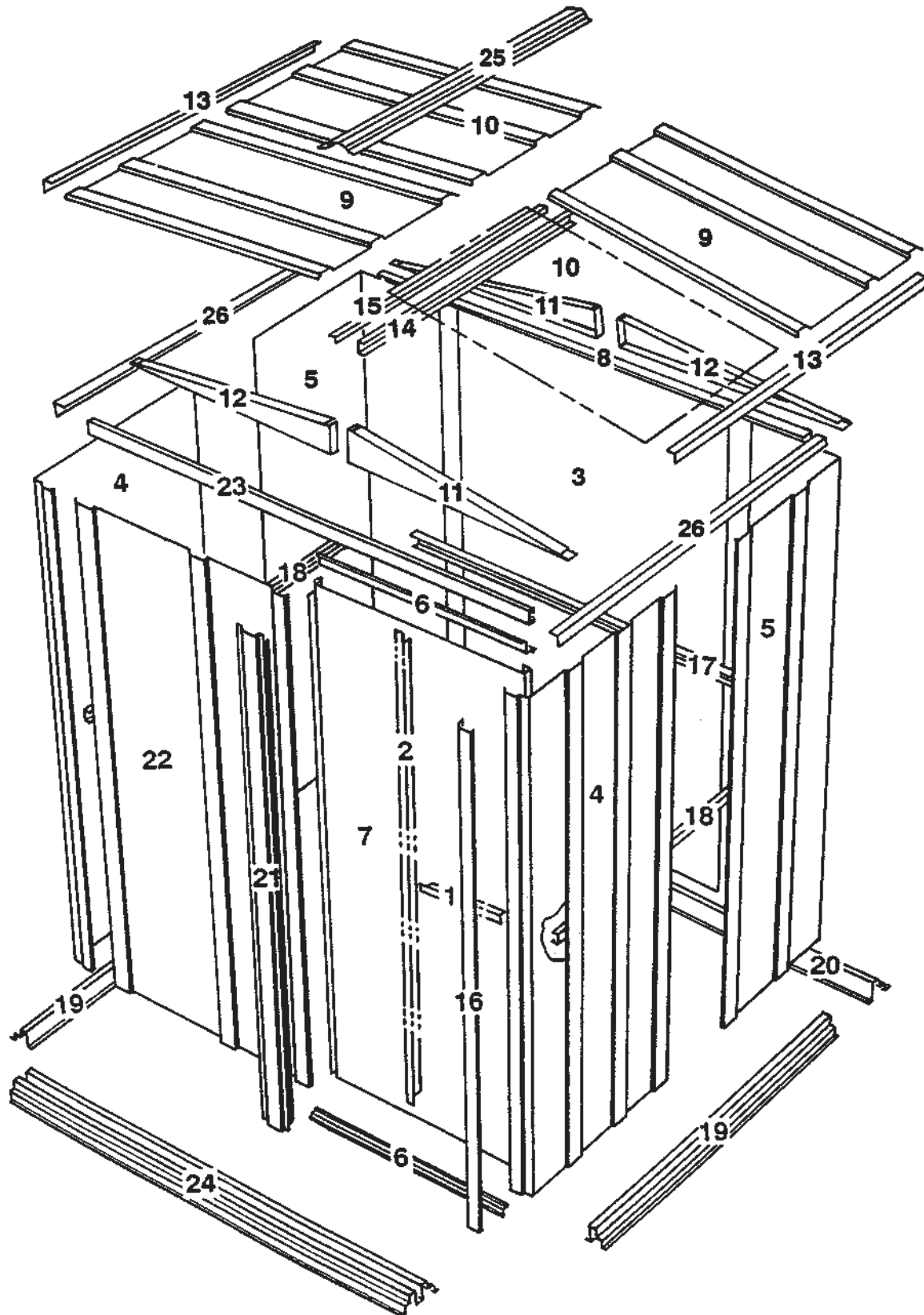

Step 1

BP14

☒ Parts Needed For ☒ Door Track/Roof Beam Assembly

- ☒ 9730 Door Track (1)
- ☒ 9729 Roof Beam (1)
- ☒ 9731 Roof Beam Angle (1)

The door track assembly supports the sliding door and reinforces the front wall. The roof beam joins the two gables and supports the roof panels. The roof beam is made up of two pieces fastened together.

Hint: The holes in the top side of the door track are for fastening the gable to the top of the front wall in a later step.

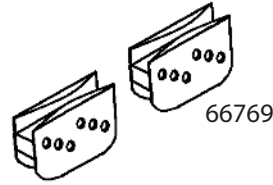

1 Position door slides onto the legs, from the end of door track, as shown in the end view.

2 Place the roof beam angle, back-to-back, with the roof beam and fasten together using six screws.

3 Set this piece aside for later use.

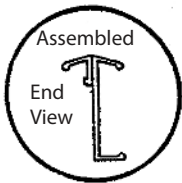
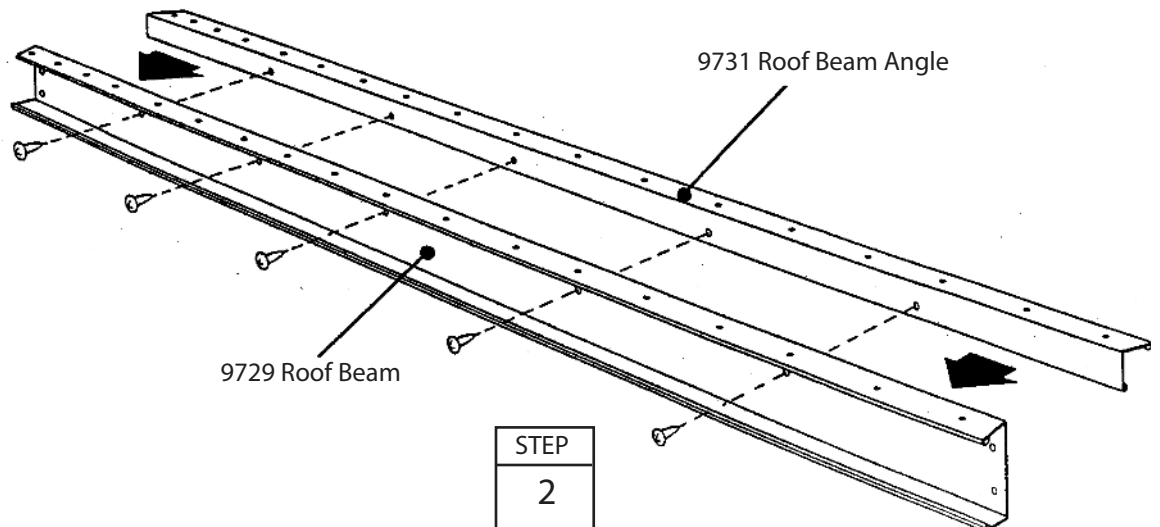
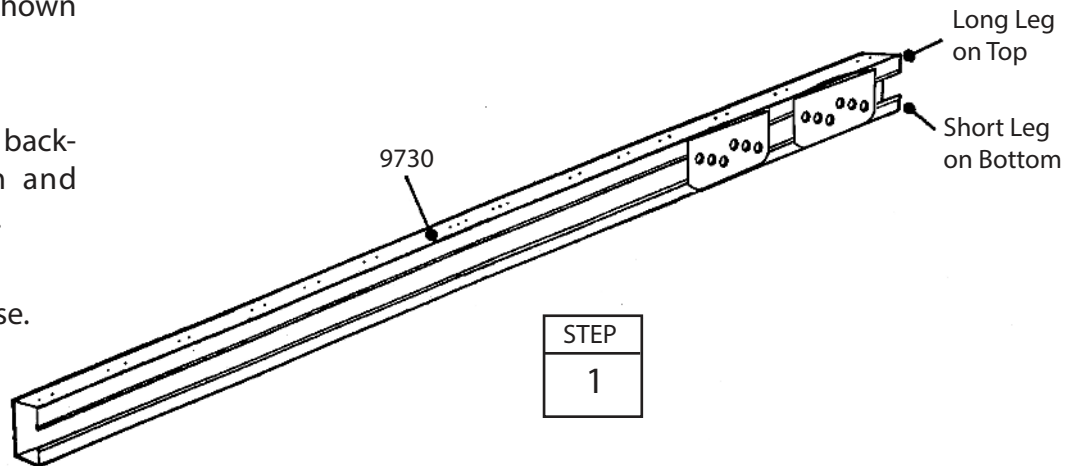

Step 2

B115

☒ Parts Needed For ☒ Floor Frame

- ☒ 9458 Front Floor Frame (1)
- ☒ 8972 Rear Floor Frame (1)
- ☒ 8971 Side Floor Frame (2)

1 Assemble the four corners of the floor frame using two screws at each corner as shown. At the front corners fasten bolts through from the bottom with nuts on top.

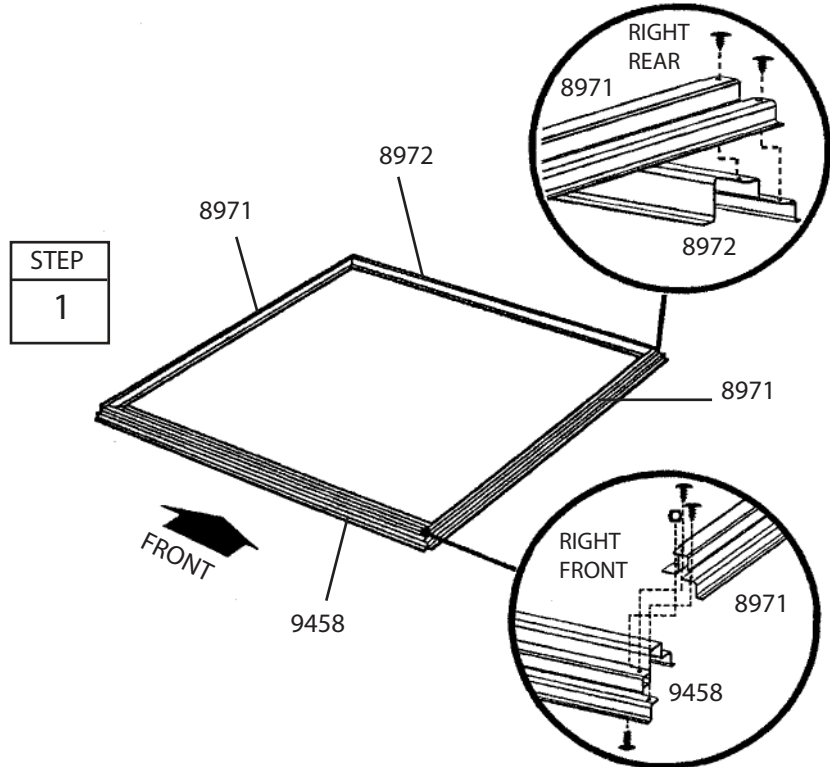

2 Measure the floor frame diagonally. When the diagonal measurements are equal, the floor frame is square.

NOTE

If using a wood platform or concrete slab do not fasten the floor frames to your base at this time. You will anchor the building after it is erected.

When Diagonal Measurements are Equal the Floor Frame is Square

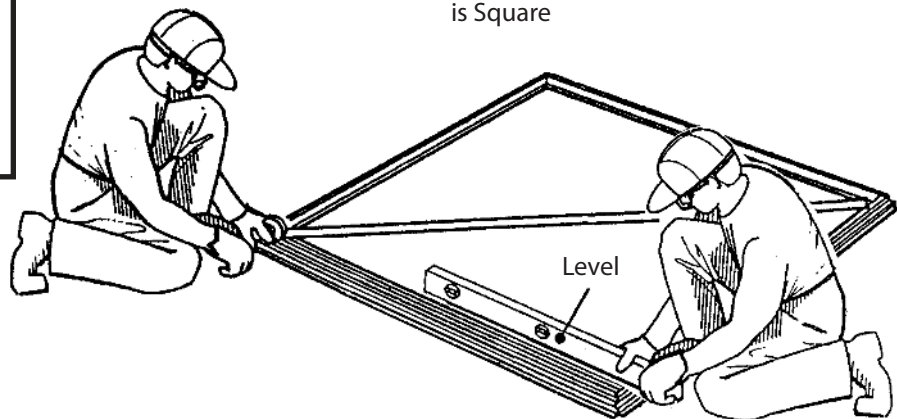

The floor frame must be square and level or holes will not align.

Step 3

☒ Parts Needed For ☒ Corners

- ☒ 7044 Corner Wall Panel (2)
- ☒ 6633 Corner Wall Panel (2)

B116

NOTE

The remainder of the building assembly requires many hours and more than one person. Do not continue beyond this point if you do not have enough time to complete the assembly today. A partially assembled building can be severely damaged by light winds.

Each screw and bolt in the wall requires a washer.



CORRECT



INCORRECT

1 Position rear corner panels at the corners of the floor frame as shown. The widest part of each corner panel must be placed along side of the building. Fasten corner panels to the floor frame using four screws.

Support the corner panel with a step ladder until overlap is fastened.

2 Attach the front corner panels to the front corners, as shown. The crimped rib should go under the rib of the adjacent panel. Fasten overlapping rib using 2 screws and a bolt with nut.

NOTE

Be careful to install the correct panel in each position as shown.

3 Double-check the part numbers of the corner wall panels, before proceeding.

The floor frame must be square and level or holes will not align.

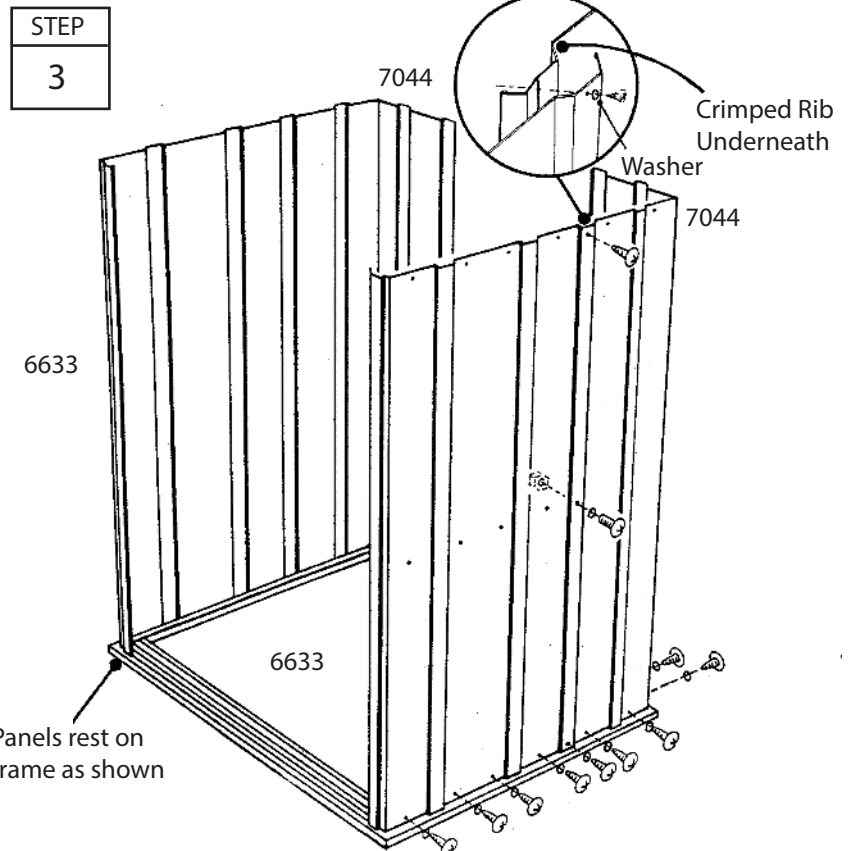
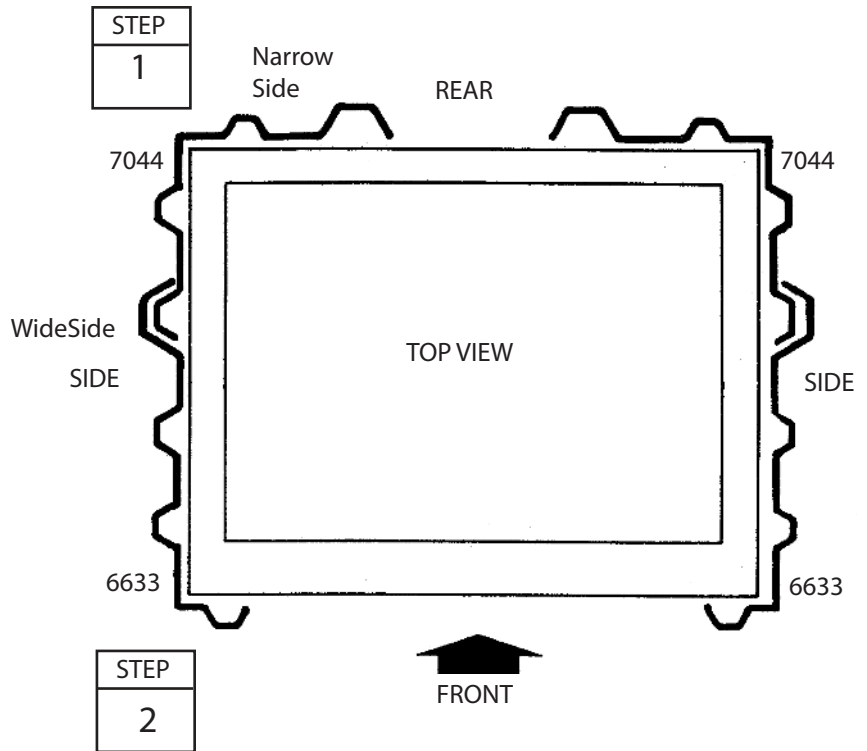

Step 4

BP17

☒ Parts Needed For ☒ Frames

- ☒ 9725 Rear Wall Angle (1)
- ☒ 9918 Rear Wall Channel (1)
- ☒ 9919 Side Wall Channel (2)

The main frame pieces give rigidity to the side and rear walls and provide a surface for attaching the gables which support the roof.

1 Fasten the rear wall angle across the top of the rear wall using screws.

2 Fasten the rear wall channel across the middle of the rear wall using screws.

3 Fasten the side wall channels across the middle of the side panels using screws. Fasten overlaps in rear corners with bolts and nuts.

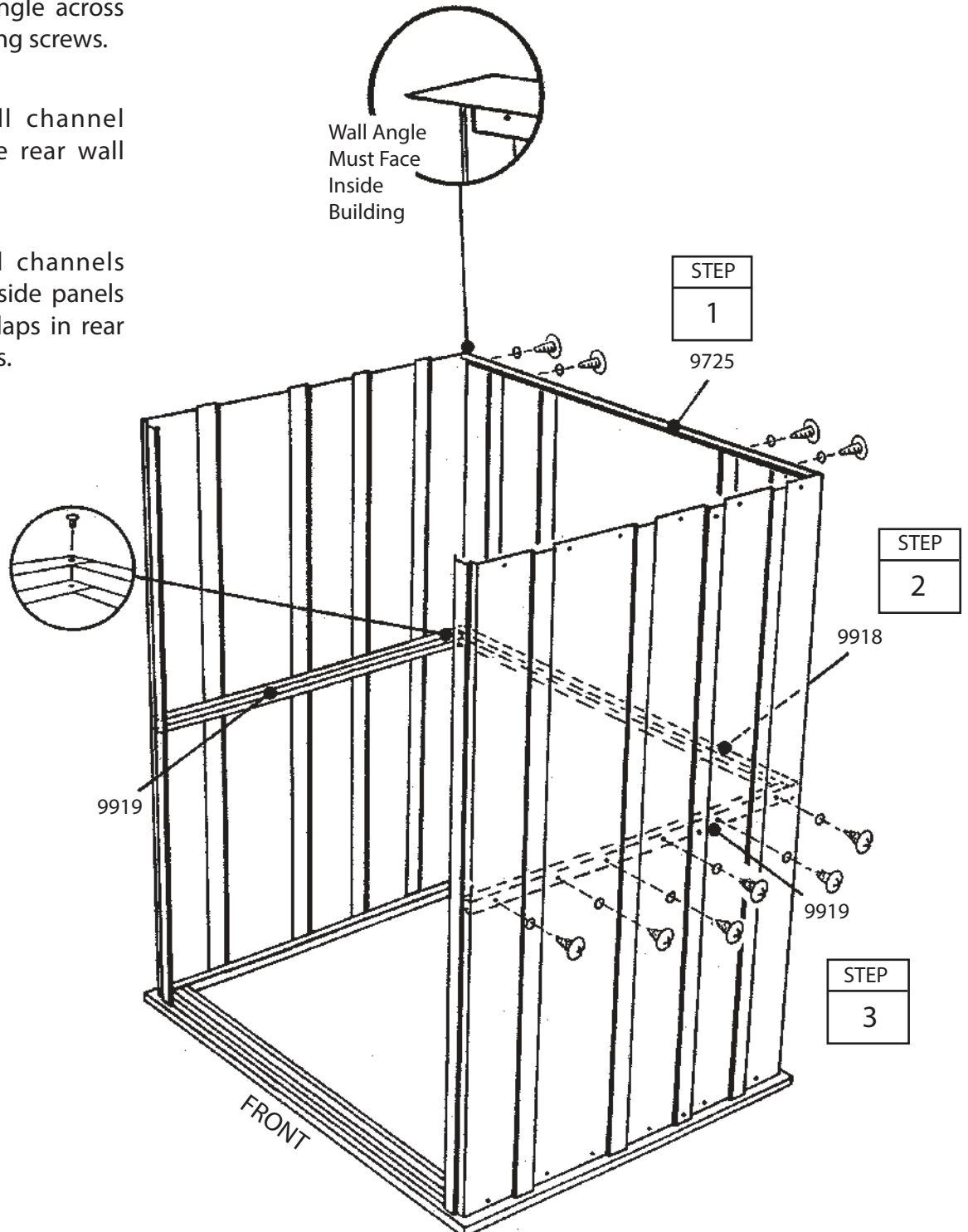

Step 5

BP18

☒ Parts Needed For ☒ Panels/Track/Jambs

- ☒ 9456 Front Wall Panel (1)
- ☒ Door Track Assembly (1)
- ☒ 9698 Door Jamb (1)
- ☒ 9370 Door Jamb (1)
- ☒ 6627 Wall Panel (1)

Each wall panel has a crimped rib on one side. The crimped rib should go under the rib of the adjacent panel. The door jambs reinforce the door opening and provide an attractive trim.

1 Fasten the front wall panel to the left front corner, as shown. Fasten overlapping rib as before.

2 Fasten the door track assembly across the top of the front wall panel using screws. See the figure.

3 Fasten the center of the right door jamb to the right corner panel with a bolt and nut. Fasten the top of the jamb to the door track with a 7/8" (22 mm) screw and a plastic spacer, as shown. Do the same for the bottom.

4 Fasten a left door jamb to the front panel with three bolts, nuts and acorn nuts, as shown. Push a plug into hole at center of jamb, closest to door opening. Fasten the top of the jamb to the door track with two screws. Do the same for the bottom into frame.

5 Fasten wall panel to the rear of building, as before.

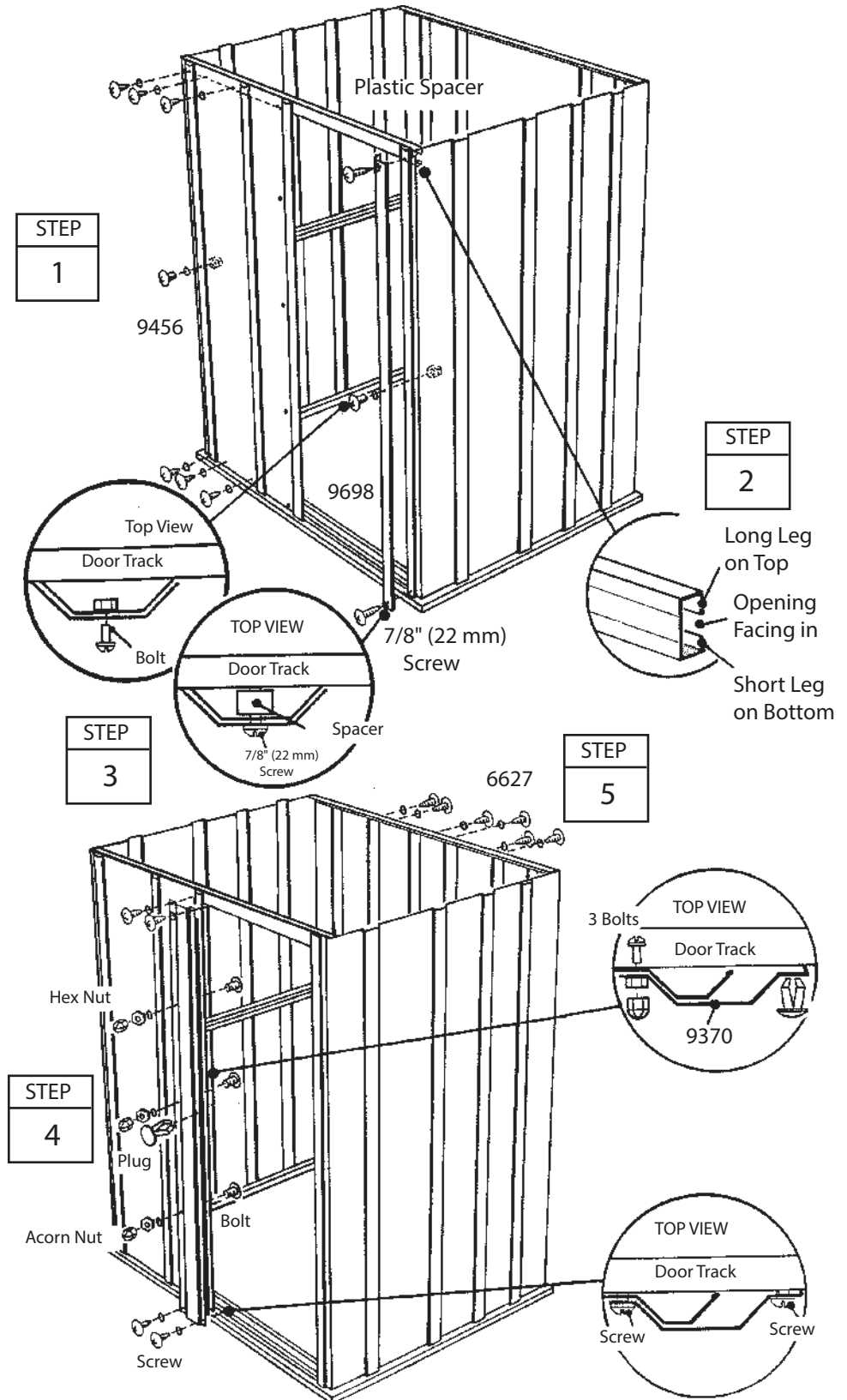

Step 6

BP19

☒ Parts Needed For ☒ Angles/Gables/Roof Beam

- ☒ 9728 Side Wall Angle (2)
- ☒ 9448 Left Gable (2)
- ☒ 9449 Right Gable (2)
- ☒ Roof Beam Assembly (1)

The gables go on top of the front and rear walls to support the roof beams.

1 Fasten the side wall angles across the top of the side panels using screws. Side wall angles must overlap rear wall angle in corners.

NOTE

The gables are packed nested together and might be mistaken as one piece. Carefully separate them before continuing.

2 Lift and fasten a right and left gable, under angle at corner, to the door track with screws.

3 Join the left and right gables together using bolts and nuts in the bottom 2 holes.

Repeat Steps 2 & 3 for the opposite end of building.

4 Fasten the roof beam assembly, small holes on top, to the gable legs of the front gables, with bolts & nuts.

5 Fasten the other end of the roof beam to the gable legs of the rear gables.

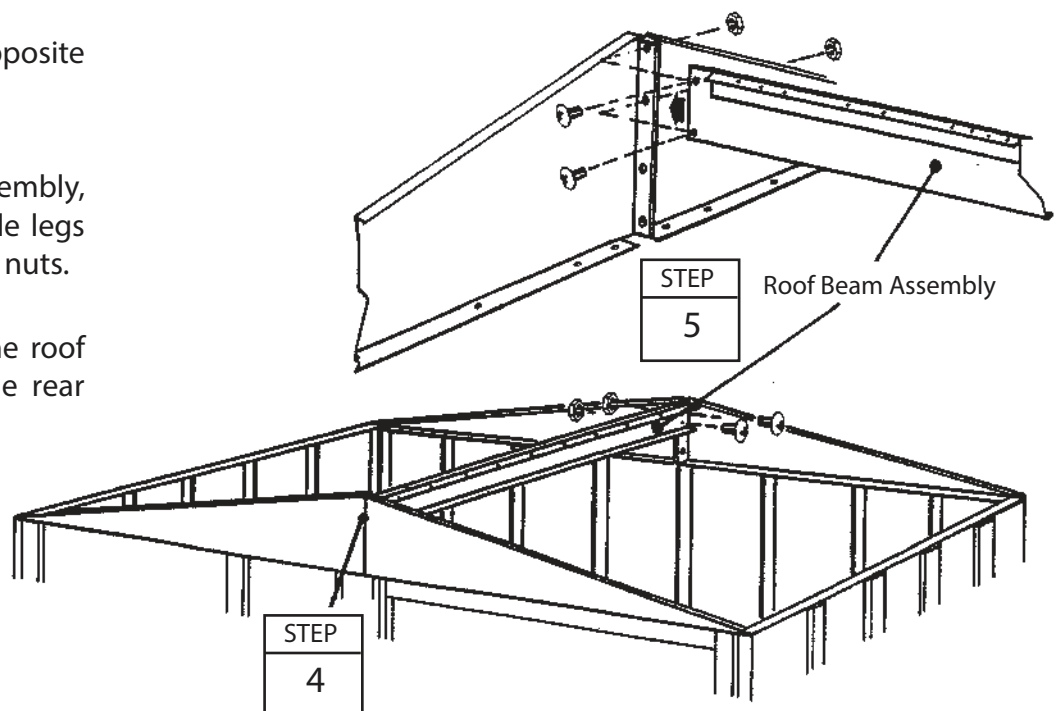
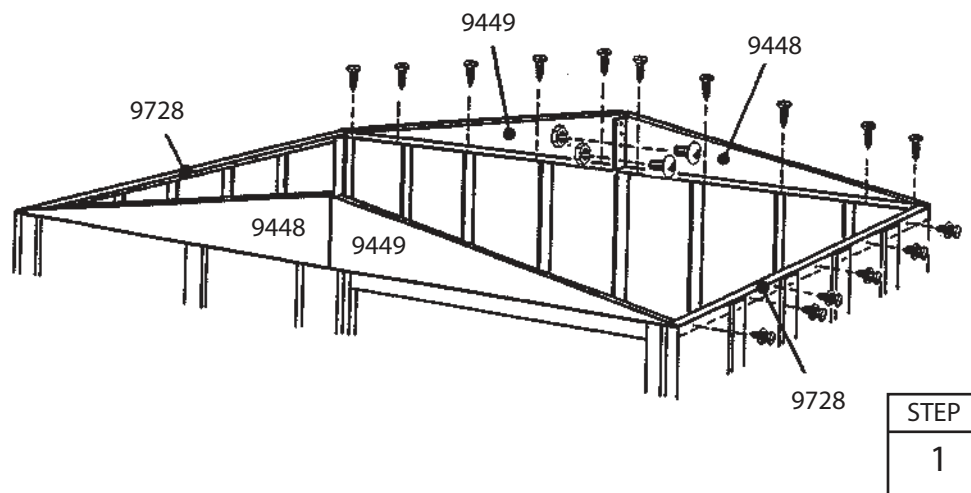
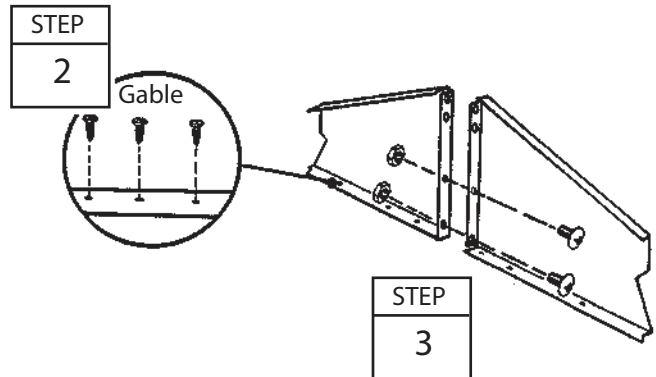

Step 7

BP20

☒ Parts Needed For ☒ Roof Assembly

- ☒ 9726 Right Roof Panel (2)
- ☒ 9727 Left Roof Panel (2)

Installing the roof panels is best done with a step ladder. Begin installing roof panels at the back right corner of the building. Each screw and bolt in the roof requires a washer.

NOTE

Measure the building diagonally again and make adjustments to make sure the building is square and level. This will make the roof panels fit better, and holes will align. Don't anchor the floor frame.

NOTE

If roof beam holes do not line up with the roof panel holes, shift the building from left to right. If this does not help, your building may not be level. Shim the corners until holes line up.



Front

1 Locate all the roof panels by their numbers and place them on the ground alongside the building in their proper positions.

2 Position a right roof panel at the back right corner and fasten to the gable and roof beam using screws as shown. Do not fasten the lower end of the panels to the side wall angles at this time.

3 Install a left roof panel at the left rear corner of the roof.

4 Cover the joint at the peak with weather stripping tape. Unroll the tape and press it down over the opening at the ridge as you install each roof panel. Do not cut the tape at this time.

5 Install a left and right roof panel in the sequence and positions shown. Follow fastener sequence.

6 Unroll the weather stripping tape, press it down firmly, and cut it.

7 Fasten the lower end of the panels to the side wall angle using screws and washers.

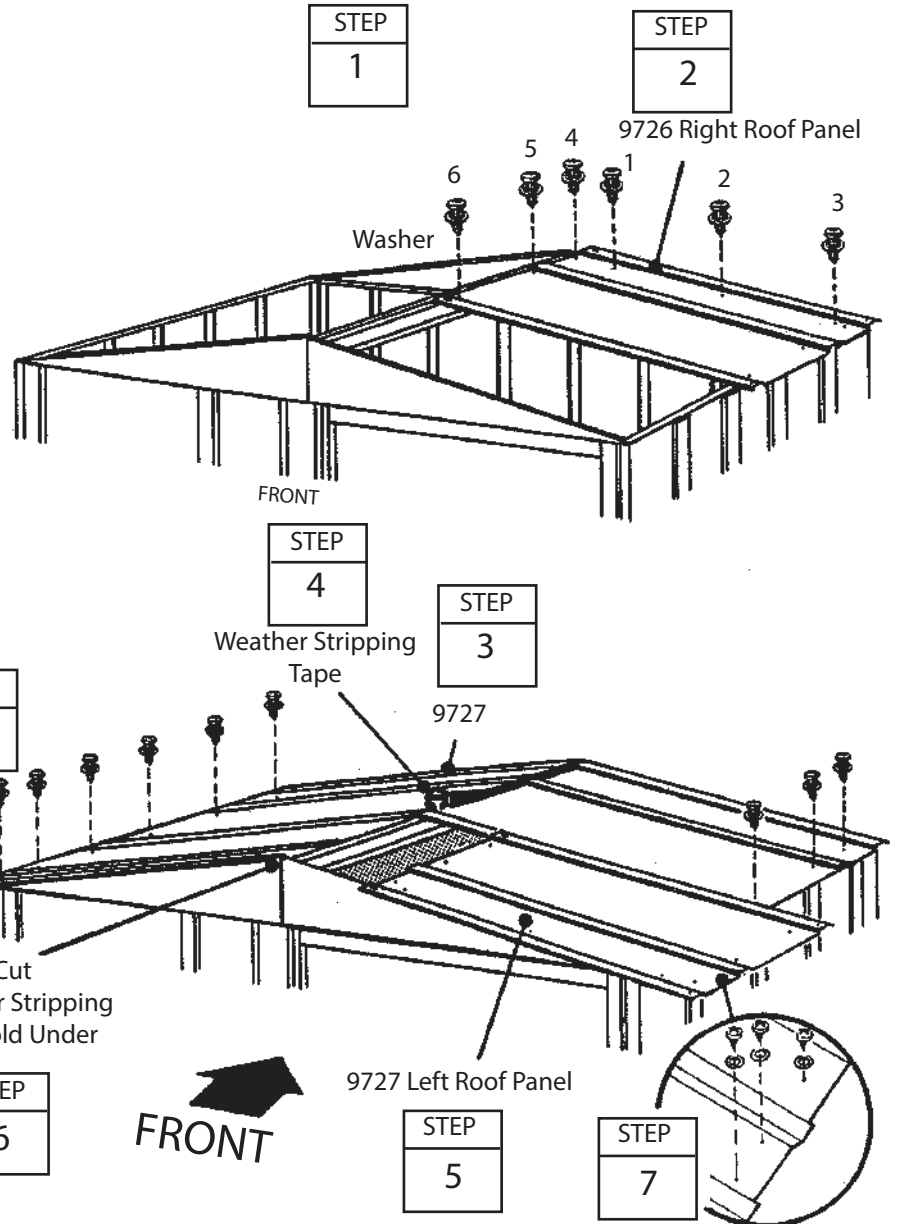

Step 8

BP21

☒ Parts Needed For ☒ Ridge Cap/Roof Trim

- ☒ 9573 Ridge Cap (1)
- ☒ 9574 Side Roof Trim (2)

1 Install the ridge cap on the completed roof section using bolts and nuts.

2 Fasten the roof panel rib, peak cap and ridge cap together using bolts and nuts. Fasten the remaining peak cap in the same manner.

3 Attach the side roof trim to the lower end of roof panels on each side of the building using screws at each panel overlap.

4 Using your thumb and index finger, overbend the bottom flange of the side roof trim at the corner inward enough so the right and left roof trim caps fit onto right and left corners.

5 Fasten the roof trim caps to the side roof trim using a screw.

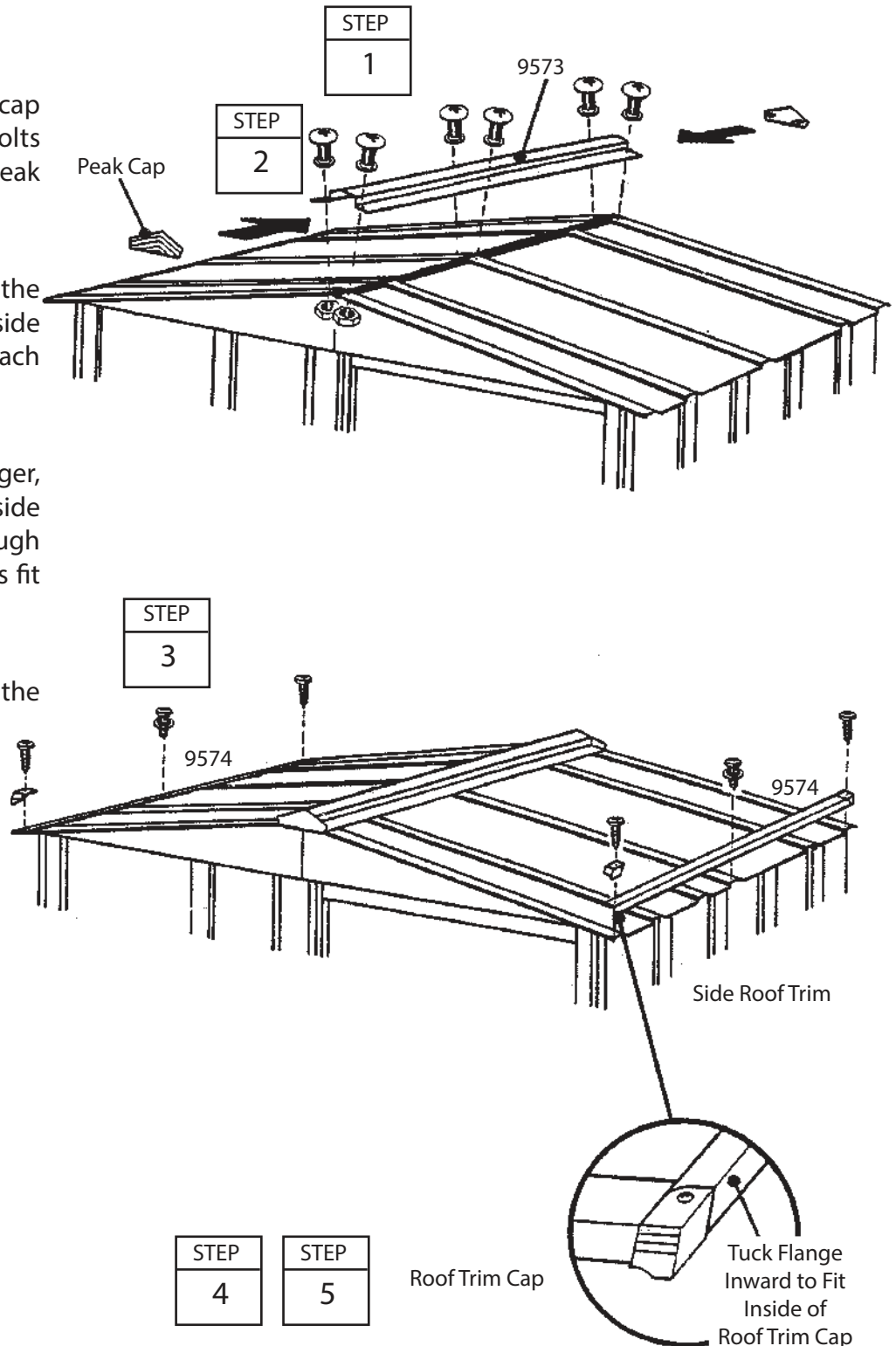

Step 9

BI22

Parts Needed For Door Assembly

- ☒ 3719 Door Handle Brace (1)
- ☒ 10473 Door (1)
- ☒ 10500 Horizontal Door Brace (2)
- ☒ 6300 Vertical Door Brace (1)

The steps on this page tell how to assemble the door. Each bolt and screw in the door requires a washer. Proceed as follows:

1 Attach the door handle brace and handle to the door with 1 bolt as shown. Don't tighten the bolt yet.

2 Swing the door handle brace up to the hole in the center of the door and insert a screw.

3 Hold the vertical door brace against the center of the inside surface of the door and turn the screw to hold the vertical door brace and door handle brace in place. Fasten to door above and below center connection using 2 screws.

4 Insert a second bolt in the door handle and tighten both bolts.

5 Put a horizontal door brace onto the top edge and bottom edge and fasten with 1 bolt in the center.

6 Attach the lower door guides and bolts as shown.

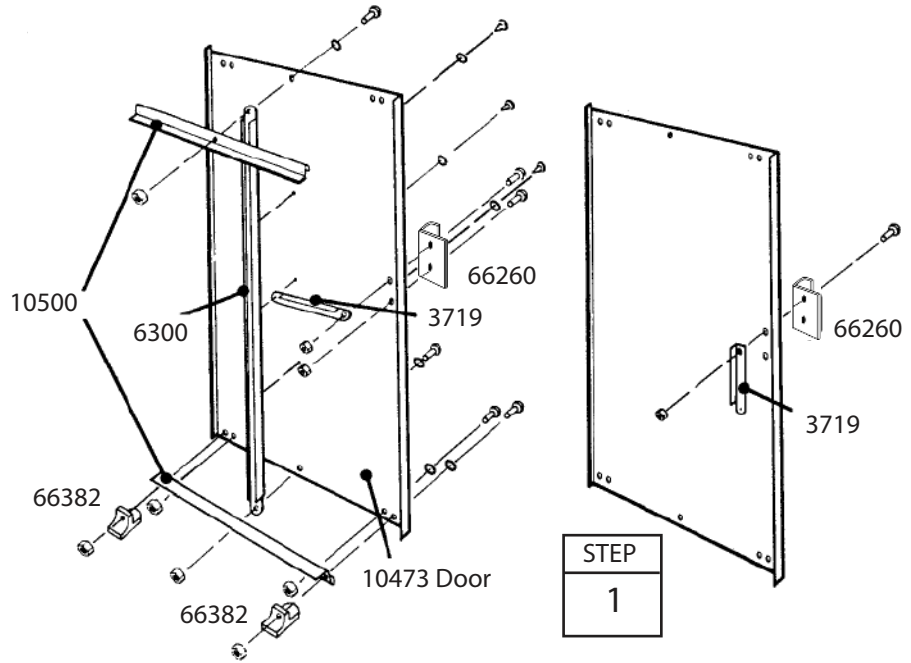

STEP
1

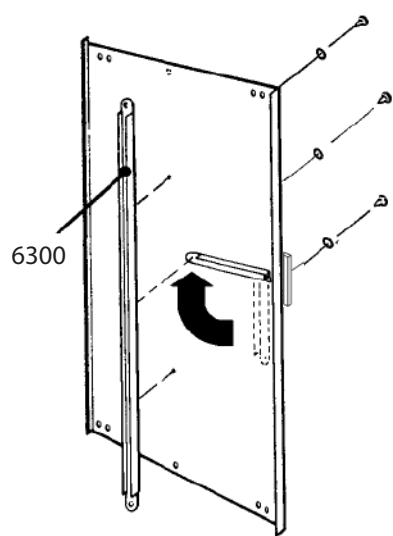

STEP
2

STEP
3

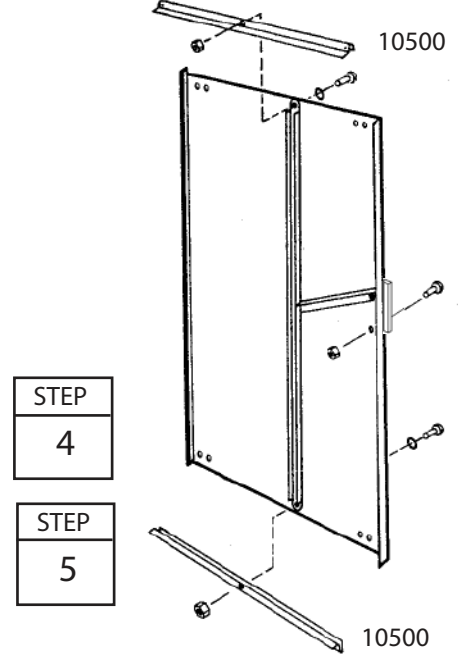

STEP
4

STEP
5

END VIEW
SHOWING:

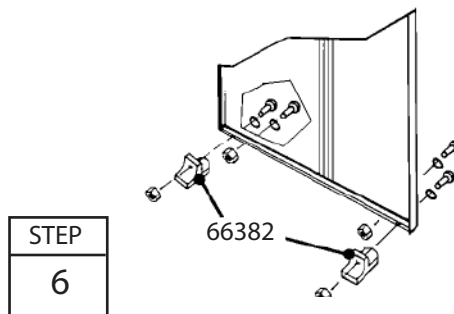

STEP
6

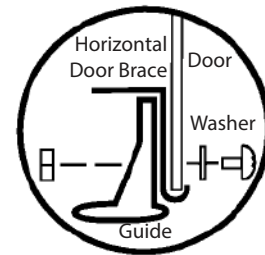

Step 10

BP23

☒ Parts Needed For ☒ Door Installation & Adjustment

- ☒ Door Assembly (1)
- ☒ 7972 Door Handle Lock Bracket (1)

1 From inside the building, put the bottom of the door assembly (on your right when you are inside the building) behind door jamb into the front frame track.

2 Position the top of the door so that the holes in the door line up with the holes in the door slides.

3 Fasten the door to the door slides using two #10Bx1/2" (13 mm) screws per door slide.

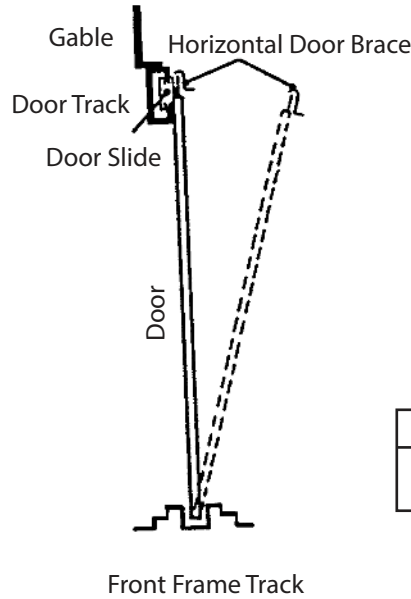

STEP
1

STEP
2

NOTE
The holes in the door slides allow you to adjust the door. Place the door in the middle holes.

4 Attach door handle lock bracket to right hand door jamb using two bolts and nuts.

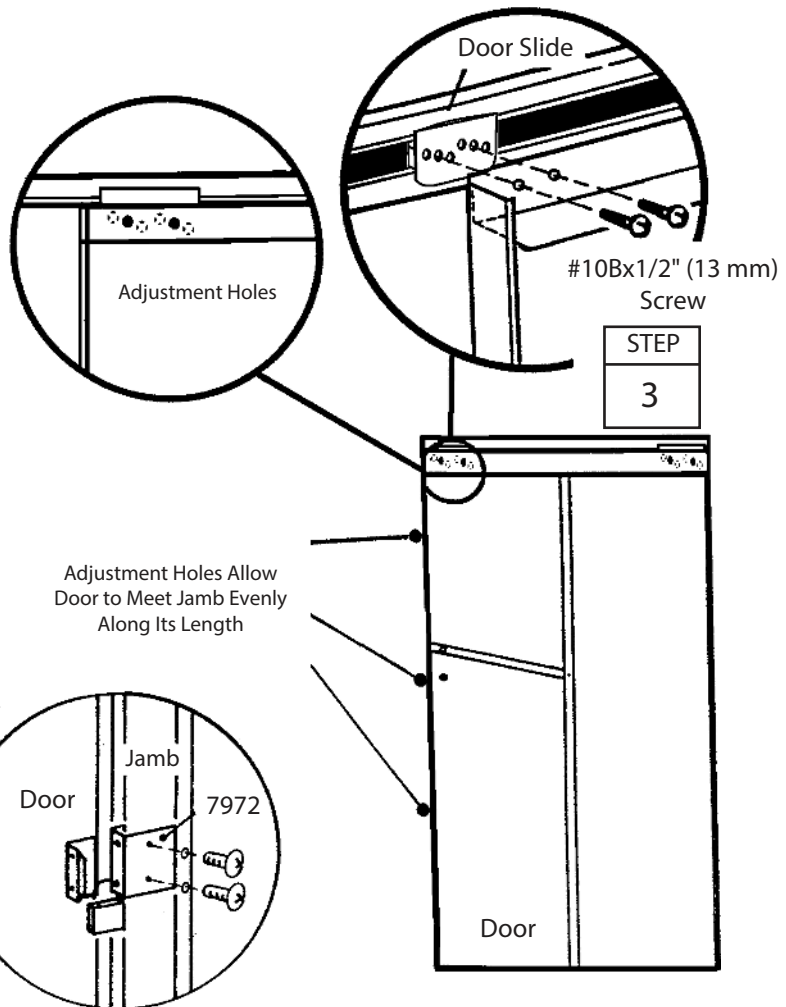

STEP
3

STEP
4

Adjustment Holes Allow Door to Meet Jamb Evenly Along Its Length

Keep this Owner's Manual and Assembly Instructions for future reference.

EH54-A	EN54	HM5467	LM5467	RM54-A
RMG54	RMW54	VL5467	WL54	NW54
RMG54Z	SE5467	RMG54EU	SE5467EU	WL54EU

BP24

Anchoring and Floor Frame

Anchoring

Anchor your building at this time.

Floor Frame

If you have purchased a Floor Frame Kit you need to install it at this time.

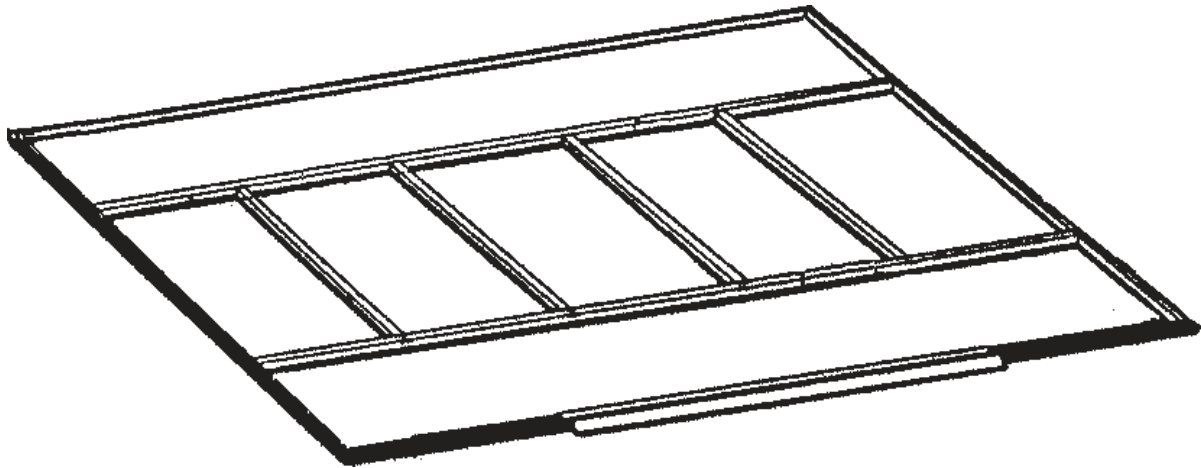

SOME FACTS ABOUT RUST

Rusting is a natural oxidizing process that occurs when bare metal is exposed to moisture. Problem areas include screw holes, unfinished edges, or where scrapes and nicks occur in the protective coating through normal assembly, handling and use. Identifying these natural rusting problem areas and taking some simple rust protection precautions can help to stop rust from developing, or stop it quickly as soon as it appears.

1. Avoid nicking or scraping the coating surface, inside and out.
2. Use all the washers supplied. In addition to protecting against weather infiltration, the washers protect the metal from being scraped by the screws.
3. Keep roof, base perimeter and door tracks free of debris and leaves which may accumulate and retain moisture. These can do double damage since they give off acid as they decay.
4. Touch up scrapes or nicks and any area of visible rust as soon as possible. Make sure the surface is free of moisture, oils, dirt or grime and then apply an even film of high quality touch-up paint.